

# KITCHEN LINE OPTIMA

a compact heat-recovery kitchen hood with air re-heat and integrated air supply



**Kitchen hoods OPTIMA with heat recovery efficiency up to 75 %** efficiently extract and filter waste air, at the same time conveniently supplying re-heated fresh air to kitchens of all sizes and configurations, with automatic operation. Compared with the standard range they additionally include **integrated electrical re-heaters or water-to-air heat exchangers** to heat or cool supply air.



OPTIMA kitchen hoods are supplied as complete units or in parts (to be assembled on site). They are made of stainless sheet metal CSN 17240 (AISI 304). All-stainless separators with aerosol-capturing efficiency up to 99 %, with dimensions 400 x 400 mm.

As a standard feature, our kitchen hoods are fitted with LED lights, with protection class IP 65, temperature resistance up to 80 °C and condensate and grease drainage. The number of lights is designed to provide luminous intensity 500 lx on the work top.

The top part of the kitchen hood has special, easily removable heat recovery exchanger. At the front, the kitchen hood has electrical PTC re-heaters or water-to-air heat exchangers for treating fresh air to the required temperature.

In addition, the kitchen hoods have a bypass damper (a bypass option for summer) with Belimo **actuator** as a standard feature. The front section includes outlet louvres for the uniform supply of fresh air. Located at the top, exhaust and supply outlets are circular or rectangular. The ductwork to be connected should have thermal and acoustic insulation and access for cleaning and maintenance through inspection panels.

## LEGEND

- $e_1$  ... outdoor fresh filtered air inlet
- $e_2$  ... fresh pre-heated air outlet to kitchen
- $i_1$  ... extracted air from kitchen hood
- $i_2$  ... discharge of waste air from kitchen hood
- K ... condensate drain from kitchen hood
-  ... LED lights (standard feature)
- BP ... bypass damper (summer and winter operation setting)
- MP ... manipulation space
- aM-XK ... automatic control module
- RG ... automatic control system switchboard
- CP 10 RT... control panel
- Mi ... exhaust EC fan
- Me ... supply EC fan with filter
-  ... electrical PTC heater / water-to-air heat exchanger
- \* ... overlap of at least min. 300 mm of kitchen hood bottom edge over appliances

Supply and exhaust **EC fans** with filters are installed away from the kitchen (mainly due to acoustic reasons).

OPTIMA kitchen hoods have a standard height of 690 mm, with plan dimensions to meet client requirements within the specified range; customized non-standard dimensions are available.

## Automatic control system aMotion

OPTIMA kitchen hoods are equipped with a complete microprocessor control system aMotion, which ensures economical operation of ventilation depending on on the immediate heat production of the kitchen appliance and thus avoids uneconomical operation of the fans when not cooking or when reduced heat load.

The key principle of automatic control is temperature detection above appliances and in the kitchen. If these temperatures are not different, fans run at only a minimum speed level in order to provide the basic air change rate in the kitchen and the operation of gas appliances is allowed. When the temperature difference between sensors increases, both the exhaust and supply fan automatically start running at a higher capacity level. If the temperature difference increases further, the speed of both fans continuously increases until it reaches the maximum level. When the difference decreases, their power level is automatically lowered or is reduced all the way down to the basic minimum air change rate. The system is described in detail on a separate data sheet. **OPTIMA kitchen hoods are not supplied without a control system.**

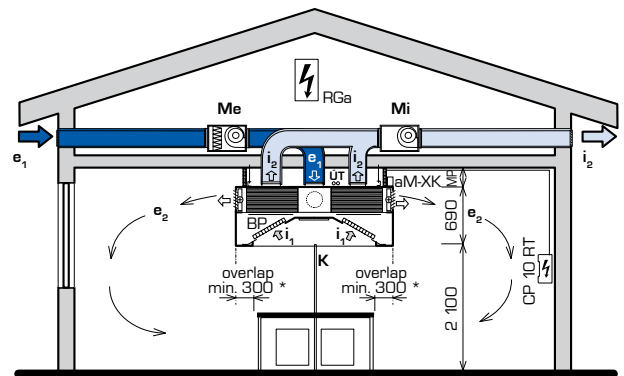

## Selection software

For the detailed selection of ventilated ceilings, kitchen hoods, accessories and control systems we recommend using our specialised selection software.

You will find it on our website [www.atrea.eu](http://www.atrea.eu).

**Atrea**®

## OPTIMA-1M (1-MODULE)

1 - MODULE ... L = 1 250 to 2 250 mm

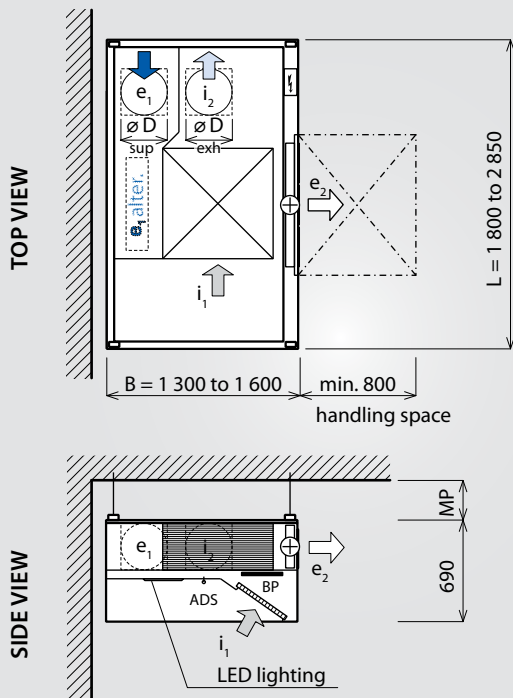

## HEATING WATER DISTRIBUTION AND CONNECTION

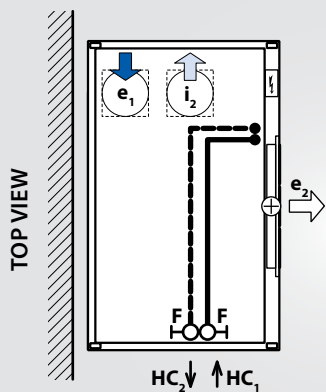

The diameter of the connecting pipe is 1", the pipe up to the ball valve is supplied by ATREA.

Standard connecting points to the CH system are shown; different positions available on request.

## WEIGHT

$G_{\text{kitchen hood}} = \sim L \times B \times (70 \text{ to } 90 \text{ kg} / \text{m}^2 \text{ of plan})$

$G_{\text{separator}} = \sim 2,8 \text{ kg} / \text{pc}$

## SUSPENSIONS

Number of  $\varnothing 10 \text{ mm}$  suspensions

1-module ... 4 pcs

## BASIC DIMENSIONS

Kitchen hood dimensions			Maximum air flow rate (m <sup>3</sup> /h)
Length L (mm)	Width B (mm)	Height (mm)	
1 800	1 300, 1 450, 1 600	690	1 500
2 000	1 300, 1 450, 1 600	690	2 000
2 250	1 300, 1 450, 1 600	690	2 500
2 500	1 300, 1 450, 1 600	690	2 500
2 750	1 300, 1 450, 1 600	690	2 500

Kitchen hood can be supplied in customized non-standard dimensions within the following range:

**L** = 1 800 to 2 850 mm      **B** = 1 300 to 1 600 mm

## AIR FLOW RATES AND SIZING

$V_{\text{exh}} = V_{\text{sup}}$ (m <sup>3</sup> /h)	Air exhaust			Air supply	
	Outlet (mm)	LO 400x400 (pcs)	$\Delta P_{\text{exh}}$ (Pa)	Outlet (mm)	$\Delta P_{\text{sup}}$ (Pa)
1 800	$\varnothing 250$	2	57	$\varnothing 250$	86
2 000	$\varnothing 355$	4	131	$\varnothing 355$	294
2 250	$\varnothing 400$	5	181	$\varnothing 400$	443

## LEGEND

- L ... kitchen hood length
- B ... kitchen hood width
- e<sub>1</sub> ... fresh outdoor filtered air inlet
- e<sub>2</sub> ... fresh pre-heated air outlet to kitchen
- i<sub>1</sub> ... extracted air from kitchen hood
- i<sub>2</sub> ... discharge of waste air from kitchen hood
- K ... condensate drain from kitchen hood (optional)
- BP ... bypass damper (summer and winter operation setting)
- MP ... manipulation space
- ⚡ ... automatic control module aM-XK
- ⊕ ... electrical PTC heater / hot-water air heater
- ADS ... thermal load sensor
- F ... ball shot-off valve

## IMPORTANT NOTICES

- maximum temperature of extracted air 60 °C
- class B gas appliances must be vented into the chimney; they must not be vented into or through the kitchen hood
- makes sure the kitchen hood sufficiently overlaps the outline of appliances

## OPTIMA-2M (2-MODULE)

2 - MODULE ... L = 3 000 to 5 000 mm

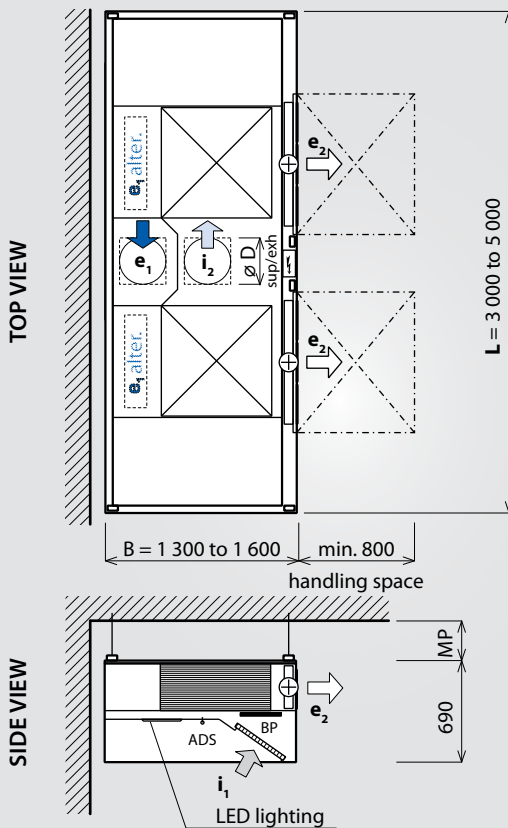

## BASIC DIMENSIONS

Kitchen hood dimensions			Maximum air flow rate (m³/h)
Length L (mm)	Width B (mm)	Height (mm)	
3 000	1 300, 1 450, 1 600	690	3 000
3 250	1 300, 1 450, 1 600	690	3 500
3 500	1 300, 1 450, 1 600	690	4 000
3 750	1 300, 1 450, 1 600	690	4 000
4 000	1 300, 1 450, 1 600	690	4 500
4 250	1 300, 1 450, 1 600	690	5 000
4 500	1 300, 1 450, 1 600	690	5 000
4 750	1 300, 1 450, 1 600	690	5 000
5 000	1 300, 1 450, 1 600	690	5 000

Kitchen hood can be supplied in customized non-standard dimensions within the following range:

L = 2 900 to 5 000 mm

B = 1 300 to 1 600 mm

## AIR FLOW RATES AND SIZING

$V_{exh} = V_{sup}$ (m³/h)	Air exhaust			Air supply	
	Outlet (mm)	LO 400×400 (pcs)	$\Delta P_{exh}$ (Pa)	Outlet (mm)	$\Delta P_{sup}$ (Pa)
2 000	∅ 355	4	82	∅ 355	111
2 500	∅ 400	5	99	∅ 400	158
3 000	∅ 400	6	127	∅ 400	212
3 500	∅ 450	7	153	∅ 450	274
4 000	∅ 450	8	181	∅ 450	344
4 500	500×400	9	211	500×400	421
5 000	550×400	10	246	550×400	505

## HEATING WATER DISTRIBUTION AND CONNECTION

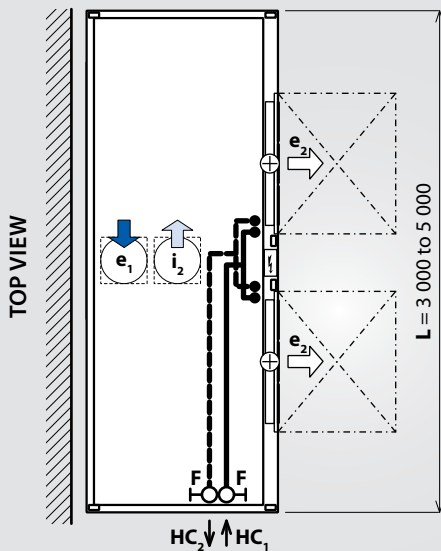

The diameter of the connecting pipe is 1", the pipe up to the ball valve is supplied by ATREA.

Standard connecting points to the CH system are shown; different positions available on request.

## LEGEND

- L ... kitchen hood length
- B ... kitchen hood width
- $e_1$  ... fresh outdoor filtered air inlet
- $e_2$  ... fresh pre-heated air outlet to kitchen
- $i_1$  ... extracted air from kitchen hood
- $i_2$  ... discharge of waste air from kitchen hood
- K ... condensate drain from kitchen hood (optional)
- BP ... bypass damper (summer and winter operation setting)
- MP ... manipulation space
- ... automatic control module aM-XK
- $\oplus$  ... electrical PTC heater / hot-water air heater
- ADS ... thermal load sensor
- F ... ball shot-off valve

## WEIGHT

$$G_{\text{kitchen hood}} = \sim L \times B \times (70 \text{ to } 90 \text{ kg} / \text{m}^2 \text{ of plan})$$

$$G_{\text{separator}} = \sim 2,8 \text{ kg} / \text{pc}$$

## SUSPENSIONS

Number of ∅10 mm suspensions

2-module ... 8 pcs

## IMPORTANT NOTICES

- maximum temperature of extracted air 60 °C
- class B gas appliances must be vented into the chimney; they must not be vented into or through the kitchen hood
- kitchen hoods with length  $L \geq 3 000$ mm should be always supplied disassembled due to difficulties in transportation and handling
- makes sure the kitchen hood sufficiently overlaps the outline of appliances

# OPTIMA 4-MODULE

## OPTIMA-4M (4-MODULE)

4 - MODULE ... L = 3 000 to 5 000 mm

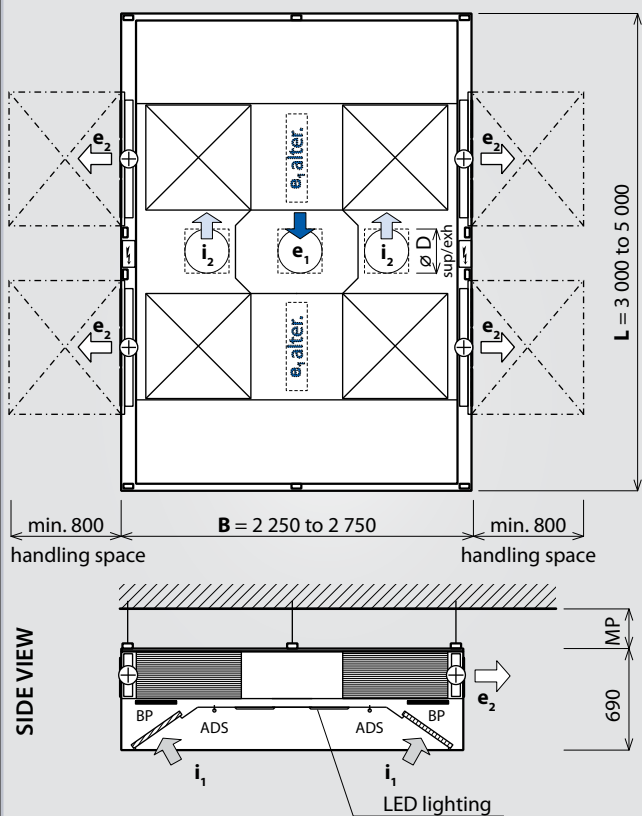

## BASIC DIMENSIONS

Kitchen hood dimensions			Maximum air flow rate (m <sup>3</sup> /h)
Length L (mm)	Width B (mm)	Height (mm)	
3 000	2 250, 2 500, 2 750	690	6 000
3 250	2 250, 2 500, 2 750	690	7 000
3 500	2 250, 2 500, 2 750	690	8 000
3 750	2 250, 2 500, 2 750	690	9 000
4 000	2 250, 2 500, 2 750	690	10 000
4 250	2 250, 2 500, 2 750	690	10 000
4 500	2 250, 2 500, 2 750	690	10 000
4 750	2 250, 2 500, 2 750	690	10 000
5 000	2 250, 2 500, 2 750	690	10 000

Kitchen hood can be supplied in customized non-standard dimensions within the following range:

**L** = 2 900 to 5 000 mm      **B** = 2 250 to 2 800 mm

## AIR FLOW RATES AND SIZING

$V_{exh} = V_{sup}$ (m <sup>3</sup> /h)	Air exhaust			Air supply	
	Outlet (mm)	LO 400×400 (pcs)	$\Delta P_{exh}$ (Pa)	Outlet (mm)	$\Delta P_{sup}$ (Pa)
5 000	2x $\varnothing$ 355	10	166	2x $\varnothing$ 355	220
6 000	2x $\varnothing$ 400	12	209	2x $\varnothing$ 400	287
7 000	2x $\varnothing$ 450	14	327	2x $\varnothing$ 450	361
8 000	2x $\varnothing$ 450	16	281	2x $\varnothing$ 450	444
9 000	2x 450×450	18	328	2x 450×450	533
10 000	2x 500×450	20	376	2x 500×450	630

## HEATING WATER DISTRIBUTION AND CONNECTION

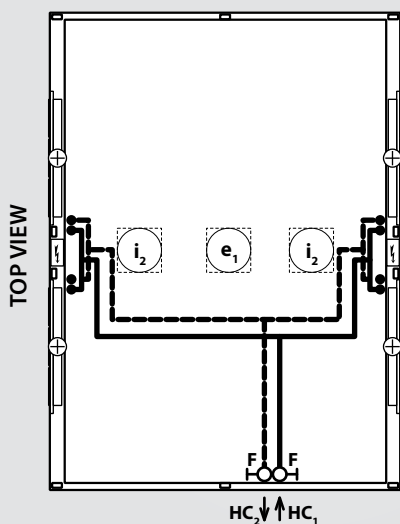

The diameter of the connecting pipe is 1", the pipe up to the ball valve is supplied by ATREA.

Standard connecting points to the CH system are shown; different positions available on request.

## IMPORTANT NOTICES

- maximum temperature of extracted air 60 °C
- class B gas appliances must be vented into the chimney; they must not be vented into or through the kitchen hood
- kitchen hoods with length  $L \geq 3\,000$  mm or width  $B > 2\,250$  mm should be always supplied disassembled due to difficulties in transportation and handling
- makes sure the kitchen hood sufficiently overlaps the outline of appliances

## LEGEND

- L ... kitchen hood length
- B ... kitchen hood width
- $e_1$  ... fresh outdoor filtered air inlet
- $e_2$  ... fresh pre-heated air outlet to kitchen
- $i_1$  ... extracted air from kitchen hood
- $i_2$  ... discharge of waste air from kitchen hood
- K ... condensate drain from kitchen hood (optional)
- BP ... bypass damper (summer and winter operation setting)
- MP ... manipulation space
- ⚡ ... automatic control module aM-XK
- ⊕ ... electrical PTC heater / hot-water air heater
- ADS ... thermal load sensor
- F ... ball shot-off valve

## WEIGHT

$$G_{\text{kitchen hood}} = \sim L \times B \times (70 \text{ to } 90 \text{ kg} / \text{m}^2 \text{ of plan})$$

$$G_{\text{separator}} = \sim 2,8 \text{ kg} / \text{pc}$$

## SUSPENSIONS

Number of  $\varnothing 10$  mm suspensions

**4-module** ... 10 pcs

BY-PASS

OPTIMA kitchen hoods are fitted with a bypass damper as a standard feature to enable summer operation without waste heat recovery. The damper is controlled using a BELIMO actuator.

WINTER MODE

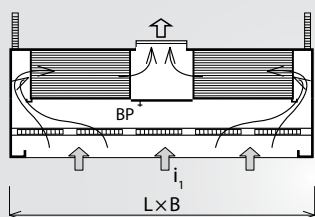

Winter

The bypass damper is closed, exhaust air  $i_1$  is extracted via the heat recovery exchanger where heat transfer takes place. Supply air  $e_1$  is pre-heated inside the heat exchanger.

SUMMER MODE

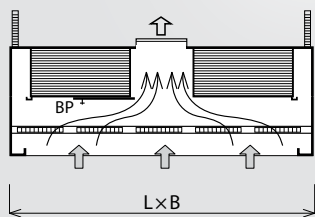

Summer

The bypass damper is open, exhaust air  $i_1$  is extracted directly, bypassing the heat recovery exchanger. Supply air  $e_1$  is not pre-heated.

ANCHORING TO THE CEILING

The kitchen hoods have special anchoring points for their suspension using M10 threaded rods fastened into the ceiling by  $\varnothing 14/10$  mm toggle bolts (not included). The anchoring points with cut-outs make it possible to easily slide the threaded rods with nuts in from the side and simply set the suspension height of the kitchen hood. For the number and type of suspension points see the diagrams.

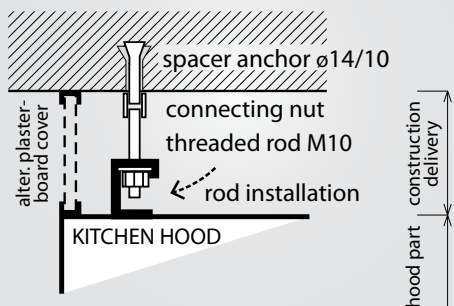

CONDENSATE DRAINAGE

Condensation forms inside the integrated heat recovery exchanger during cooling. The kitchen hood has a collection channel along its perimeter to capture this condensate. When installing the kitchen hood make sure to provide for its drainage into the sewer line. Normally, the bottom collection channel has holes for the optional installation of a stainless condensate drain pipe. The standard length of the stainless pipe including a bend is 1 500 mm, with the outer diameter of 25 mm.

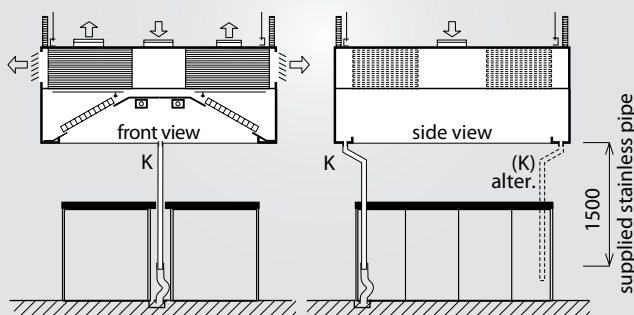

LAMELLA SEPARATORS

As a standard feature, the kitchen hoods are fitted with  $400 \times 400$  mm lamella separators. The number of separators is determined according to the graph of the maximum assumed air flow rate through the kitchen hood so that an air flow rate through one filter is always within the optimum range. Finally, it is necessary to check whether the number of filters arrived at by calculation can physically fit in the kitchen hood.

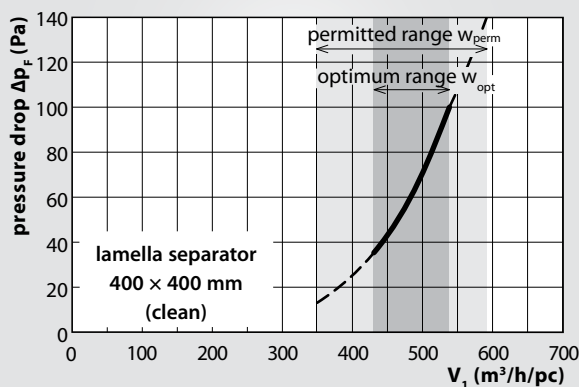

HEATING CAPACITY OF HOT-WATER AIR HEATER

The maximum heating capacity is shown for heating water with a gradient of  $80 / 60$  °C; supply air (post-heat recovery)  $+10$  °C, rh 30 %. The graph applies to each individual heat exchanger of the kitchen hood.

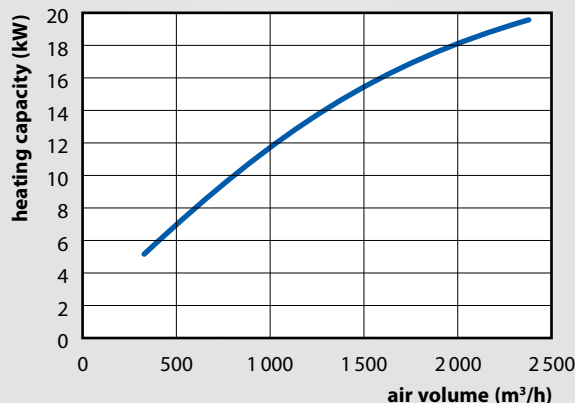

SAMPLE WIRING DIAGRAM

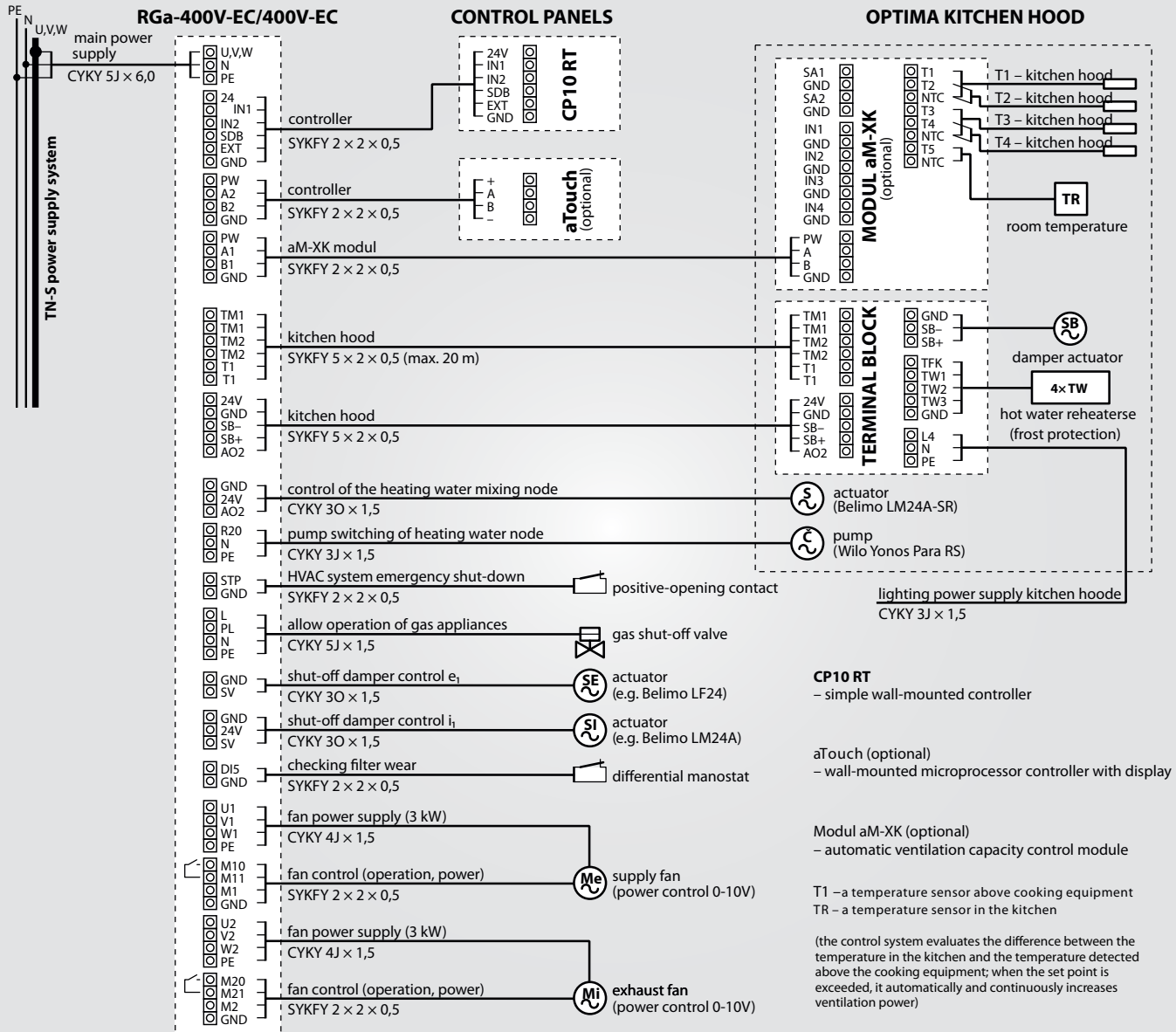

SAMPLE WIRING DIAGRAM

