

DUPLEX

1400 to 15100 Basic

All-purpose ventilation units
with cross-flow heat
recovery exchangers

DUPLEX 1400 to 15100 Basic are compact ventilation units with cross-flow heat recovery exchanger. They are solely intended for applications that do not come under the field of activity of the Committee's Regulation (EU) No. 1253/2014.

DUPLEX Basic units are produced in compact (1400 to 10100 Basic) and semi-compact (12100 to 15100 Basic) version and contain two independently controlled EC fans with backward curved blades, a heat recovery exchanger with large heat-transfer surface and high efficiency, slide-out supply and exhaust air class G4, M5 or F7 filters, drain pans and possibly also an a circulation damper with a servo drive or integrated air heaters and coolers.

Unit casing is divided into two versions:

DUPLEX 1400-10100 Basic are frameless construction, casing is made of painted metal sheet (colour RAL 9006) with 30 mm PIR insulation with heat transfer coefficient ($\lambda = 0,024 \text{ W/mK}$).

DUPLEX 12100-15100 Basic are frame construction, casing is made of painted metal sheet (colour RAL 9006) with 45 mm mineral wool insulation with heat transfer coefficient ($\lambda = 0,037 \text{ W/mK}$).

DUPLEX Basic ventilation units meet the requirements of the most stringent European standards:

- Casing properties according to EN 1886
- EC motors according to ErP 2015
- SFP < 0,45 W/(m³/h) according to PassivHaus*
- Hygienic requests according to VDI 6022



1400 to 15100 Basic

Advantages of DUPLEX Basic units:

- New design of ventilation units with excellent parameters
- Great thermal insulation of the casing (class T2)
- Reduced thermal bridging (class TB1/TB2**)
- Compact dimensions
- Very flat unit suitable for ceiling-suspended installation
- Ease of installation
- Variable configuration of discharge ports
- Unified dimensions of ports
- Optional versions with a bypass and circulation damper
- Horizontal floor-standing up to 15 100 m³/h, floor-standing flat or ceiling-suspended types up to 8 100 m³/h
- High efficiency fans – SFP < 0,45 W/(m³/h)*
- High heat recovery efficiency of the cross-flow heat recovery exchanger – up to 75 %
- Integrated control system including temperature sensors
- Integrated web server (aMotion control system only)
- Comfortable unit control with touchscreen controller
- Comprehensive selection software

* in the defined working area

** TB1 for 1400-10100 Basic
TB2 for 12100-15100 Basic

AVAILABLE MODIFICATIONS (CAN BE COMBINED)

- | | | | |
|-----|----------------------------------|-------|-----------------------------------|
| - B | with in-built bypass damper | - T | with in-built hot-water heater |
| - C | with in-built circulation damper | - CHF | with in-built direct chiller |
| - E | with in-built electrical heater | - CHW | with in-built water-based chiller |

OPERATING MODES OF DUPLEX BASIC UNITS

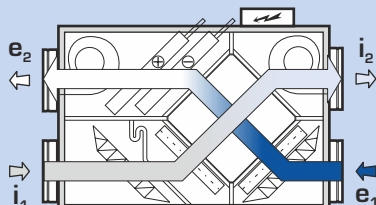

Ventilation with heat recovery
with re-heating (with cooling)

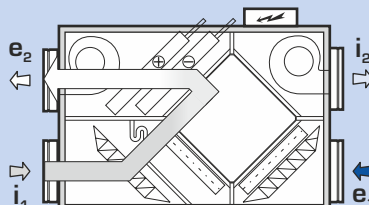

Circulation heating
or cooling

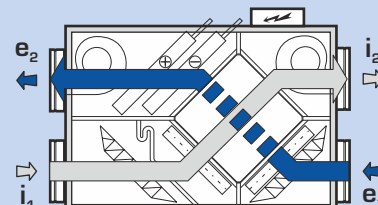

Ventilation without heat recovery
(via bypass)

→ e₁ ... Fresh outdoor air suction
⇄ e₂ ... Fresh filtered air outlet

⇄ i₁ ... Exhaust air suction
⇄ i₂ ... Exhaust air outlet

T/E... Central heating / electrical heater connection
CH ... Cooling connection

SELECTION SOFTWARE



For the detailed design of DUPLEX series units, accessories and control systems we recommend using our dedicated design software. You can find it on our website at www.atrea.eu.



UNIT VENTILATORS & HEAT RECOVERY

ATREA s.r.o., Čs. armády 32
466 05 Jablonec n. Nisou
Czech Republic



www.atrea.eu

Tel.: +420 483 368 111
Fax: +420 483 368 112
E-mail: atrea@atrea.eu

PERFORMANCE GRAPHS

DUPLEX BASIC

DUPLEX Basic		1 400	2 400	3 400	5 400	7 100	8 100	10 100	12 100	15 100
Supply air - max. ¹⁾	m ³ h ⁻¹	1 650	2 800	3 970	5 740	7 750	8 600	11 000	12 600	16 000
Extraction air - max. ¹⁾	m ³ h ⁻¹	1 660	2 780	4 200	5 800	7 580	8 500	11 100	12 550	15 950
Heat recovery efficiency ²⁾	%	up to 75 %								
Number of versions and positions	-	see table "Mounting positions", page 4								
Weight ³⁾	kg	180-260	190-270	280-360	310-380	360-440	470-550	570-660	1 250-1 380	1 470-1 650
Max. power input	kW	0,7	1,4	2,7	4,8	6,1	7,4	10,3	10,5	12,3
Voltage	V	230			400					
Frequency	Hz	50								
Revolutions - max.	min ⁻¹	3 350	2 900	2 980	2 960	2 700	2 800	2 570	2 130	1 860
Heating output E low - max. ⁵⁾	kW	2,1	2,1	4,2	7,2	7,2	9,9	9,9	-	-
Heating output E high - max. ⁵⁾	kW	4,2	4,2	8,4	10,8	12,6	14,7	14,7	-	-
Heating output T - max. ⁴⁾	kW	20	27	34	51	64	76	94	104	110
Cooling output CHW - max. ⁴⁾	kW	12	18	25	35	51	60	68	77	85
Cooling output CHF - max. ⁴⁾	kW	11	15	18	31	48	58	65	74	82

¹⁾ Maximum flow rate through units at zero external pressure

²⁾ According to air volume

³⁾ Depending on equipment

⁴⁾ Depending on register type, liquid and flow rates

⁵⁾ For detailed information please use our DUPLEX selection software.

PERFORMANCE SUMMARY

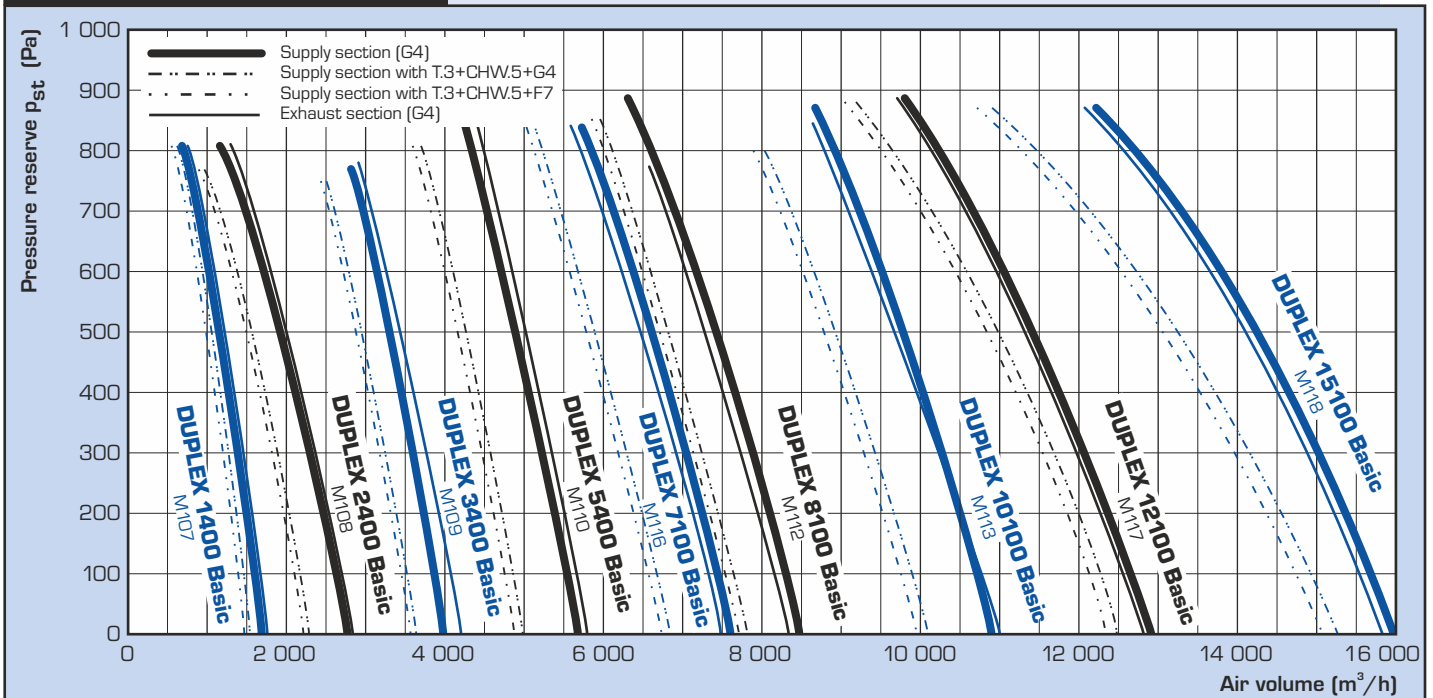

HEAT RECOVERY EFFICIENCY

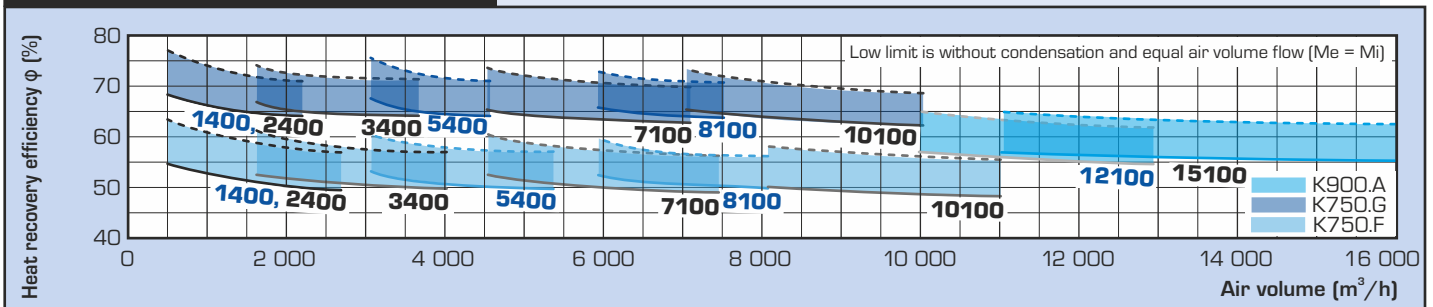

HEATING AND COOLING PERFORMANCES

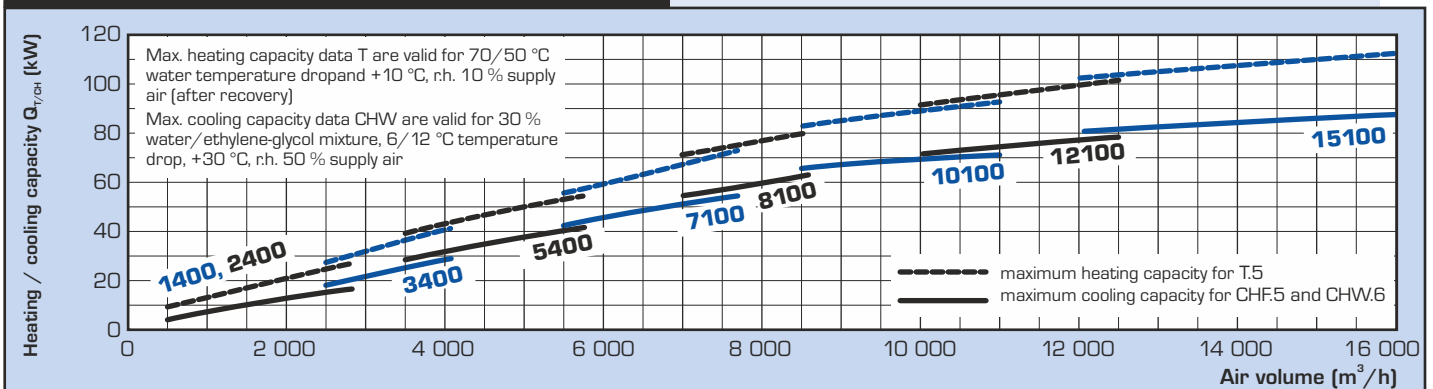

BASIC DIMENSIONS

FLOOR-STANDING (front view)
Basic 1400 to 10 100

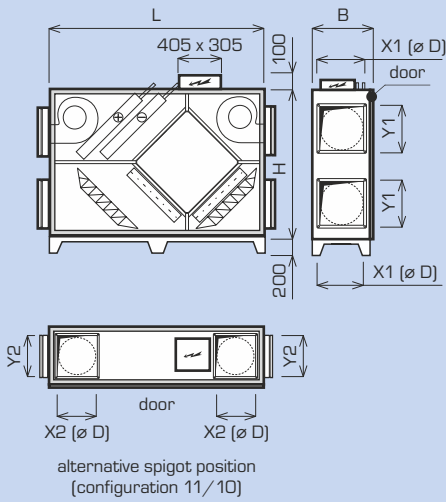

FLOOR-STANDING (front view)
Basic 12 100 to 15 100
configuration 10/x and 11/x

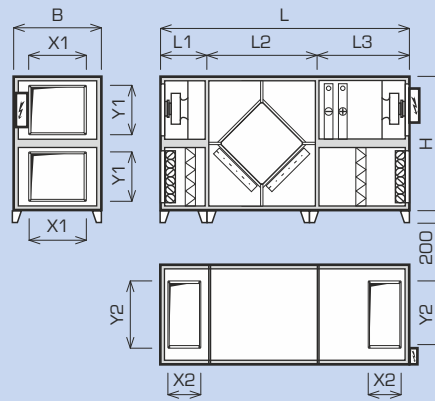

FLOOR-STANDING (front view)
Basic 12 100 to 15 100
configuration 12/x and 13/x

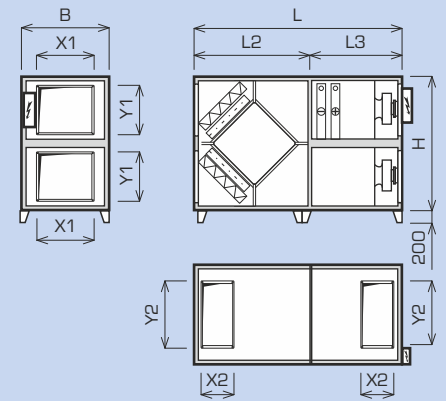

CEILING-SUSPENDED (top view)
Basic 1 400 to 8 100

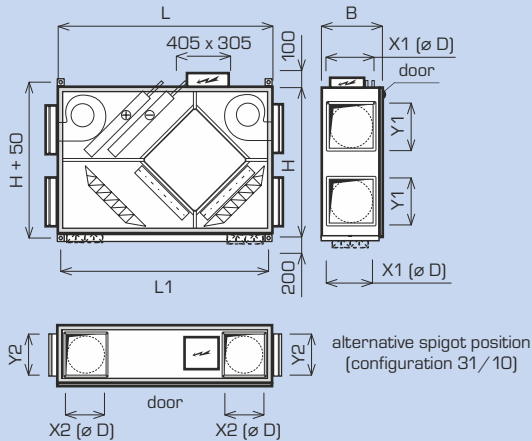

FLOOR-STANDING FLAT (top view)
Basic 1400 to 8100

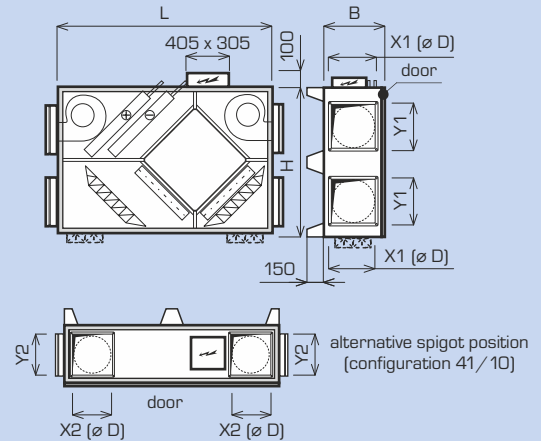

DUPLEX Basic		1 400	2 400	3 400	5 400	7 100	8 100	10 100	12 100	15 100
dimension H	mm	1 300	1 300	1 450	1 600	1 600	1 600	1 600	1 795	1 995
dimension B	mm	455	455	580	665	885	1 065	1 295	1 620	1 790
length L	mm	2 100	2 100	2 300	2 300	2 500	2 500	2 500	3 670 / 2 998**	3 850 / 3 050**
length L1	mm	2 070	2 070	2 270	2 270	2 470	2 470	2 470	671	800
length L2	mm	-	-	-	-	-	-	-	1 702	1 702
length L3	mm	-	-	-	-	-	-	-	1 296	1 348
condensate drain	mm	ø 32								
Connecting ports										
dimension X1 x Y1 (standard e, i)	mm	ø 315	ø 315	300 x 400	400 x 400	500 x 500	500 x 500	700 x 500	900 x 710	900 x 710
dimension X2 x Y2 (atyp e, i)	mm	ø 315*	ø 315*	400 x 300	400 x 400	500 x 500	500 x 500	500 x 700	400 x 1200	400 x 1200

* Dimension X2 x Y2 (port e, i) for non-standard configuration: 400 x 200 mm. For detailed design and technical data we recommend using our dedicated selection software.
** For configuration 12/x and 13/x is L = L2 + L3

TYPES AND DIMENSIONS OF CONNECTING PORTS

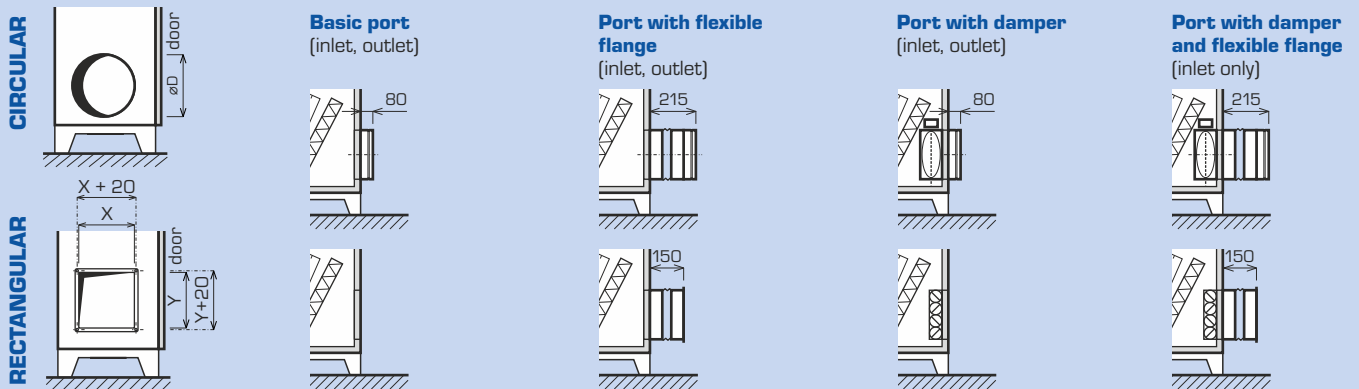

INSTALLATION AND VERSIONS

INSTALLATION VERSIONS AND CONNECTING PORTS

DUPLEX 1400 to 15100 Basic units are available in a range of versions to facilitate their installation in the machine room. This significantly increases options to install DUPLEX Basic units in cramped spaces.

For structural reasons and to ensure condensate drain it is not possible to have all units available in all mounting positions. Detailed drawings are shown in the summary table "Mounting positions".

DUPLEX Basic units are characterised by a wide range of accessories – the ports may be optionally fitted with flexible flanges and inlet ports may have shut-off dampers if required.

MOUNTING POSITIONS

FLOOR-STANDING HORIZONTAL POSITION

Basic 1400 to 15100

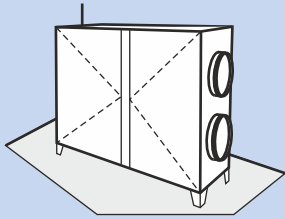

configuration 10 to 12 – door-side view

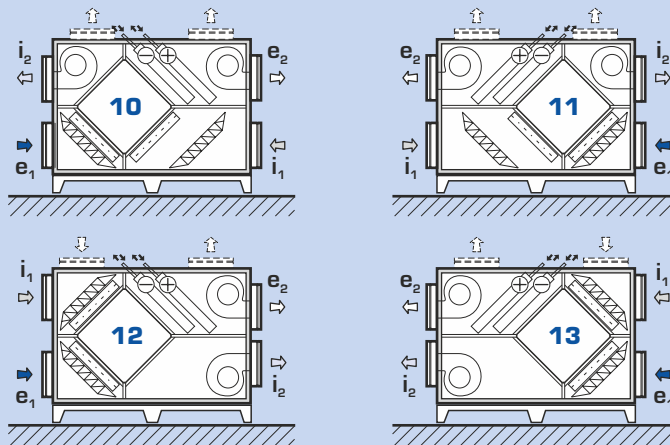

CEILING-SUSPENDED POSITION

Basic 1400 to 8100

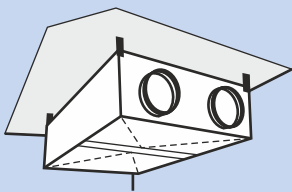

configuration 30 to 33 – top view

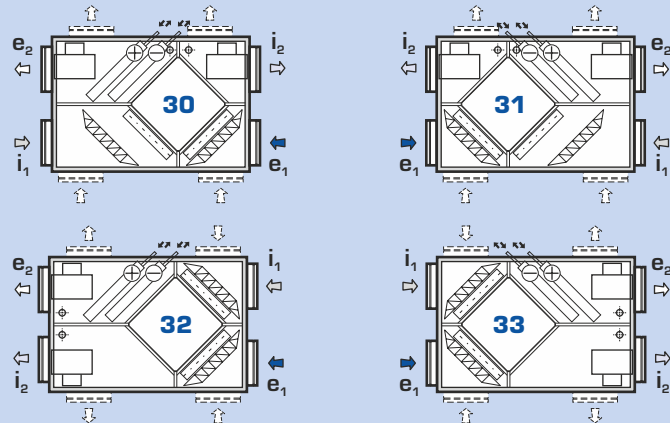

FLOOR-STANDING FLAT POSITION

Basic 1400 to 8100

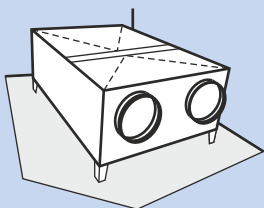

configuration 40 to 43 – top view

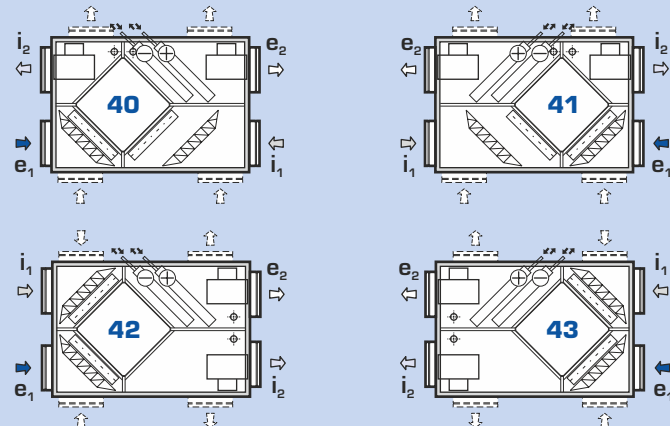

Note: For detailed design and technical data we recommend using our dedicated selection software.

HANDLING SPACE

DUPLEX units must be installed with the prescribed handling space around the unit in mind. Below the unit at least 150 mm must be left to install the DN 32 condensate drain line. This line must run through a U-bend at least 150 mm high into a sewer. This space is easily provided when the steel supporting feet supplied as standard are used. Handling space in front of the unit must be maintained for opening the front door, replacing filters and providing servicing and installation access to each unit part.

Each drawing shows the minimum handling space. In addition, each unit must have the minimum handling space of 600 mm from the side of the control system electric switchboard according to CSN. Units with a heating or cooling control manifold must have free space from the side of the manifold, too.

Handling space in front of the door

**Floor-standing horizontal
1400-10100 Basic**

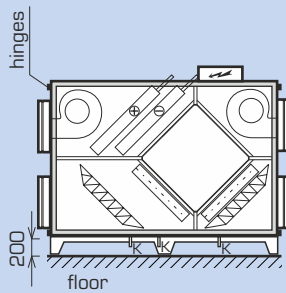

**Floor-standing horizontal
12100-15100 Basic**

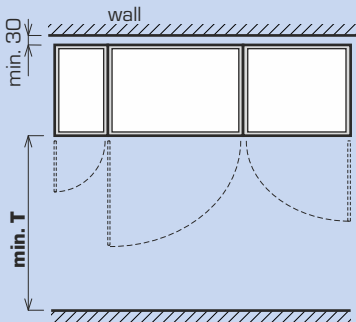
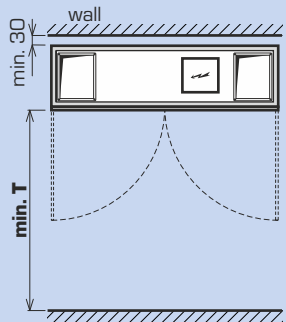
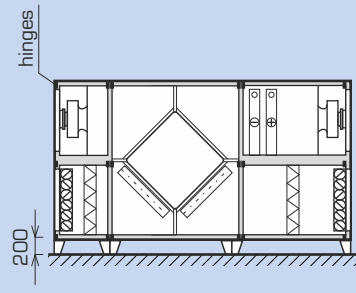

**Floor-standing flat
1400-8100 Basic**

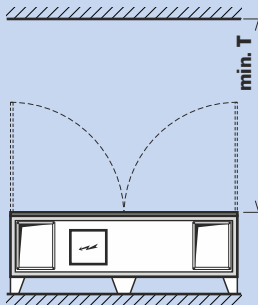

**Ceiling-suspended
1400-8100 Basic**

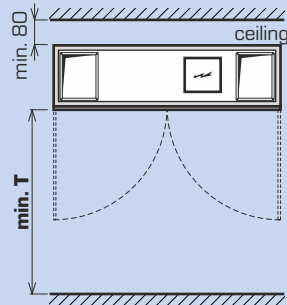

Handling space for accessories

Control modules

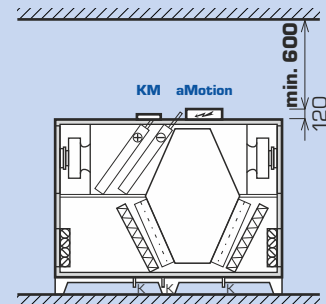

Control manifolds for coils

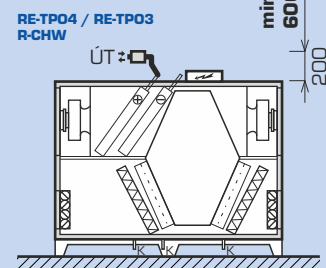

Type	standard door T (mm)	hingeless door T (mm)
DUPLEX 1400 Basic	1 000	500
DUPLEX 2400 Basic	1 000	500
DUPLEX 3400 Basic	1 200	600
DUPLEX 5400 Basic	1 200	700
DUPLEX 7100 Basic	1 300	900
DUPLEX 8100 Basic	1 300	1 100
DUPLEX 10100 Basic	1 500	1 300
DUPLEX 12100 Basic	-	1 600
DUPLEX 15100 Basic	-	1 700

ACOUSTIC POWER L_w AND ACOUSTIC PRESSURE L_{p1}

Type	Working point	Acoustic power L_w [dB(A)]					Acoustic pressure L_p [dB(A)] at distance of 3 m
		inlet e_1	inlet i_1	outlet e_2	outlet i_2	unit	
DUPLEX 1400 Basic	1 000 m ³ /h (200 Pa)	51	55	77	76	50	30
DUPLEX 2400 Basic	2 000 m ³ /h (200 Pa)	55	65	86	88	56	35
DUPLEX 3400 Basic	3 000 m ³ /h (200 Pa)	73	69	95	88	67	47
DUPLEX 5400 Basic	4 500 m ³ /h (200 Pa)	77	64	98	85	64	43
DUPLEX 7100 Basic	6 000 m ³ /h (200 Pa)	62	63	87	85	63	43
DUPLEX 8100 Basic	7 500 m ³ /h (200 Pa)	71	64	95	88	64	44
DUPLEX 10100 Basic	9 500 m ³ /h (200 Pa)	83	80	89	93	62	41
DUPLEX 12100 Basic	11 000 m ³ /h (200 Pa)	70	71	92	93	70	50
DUPLEX 15100 Basic	14 000 m ³ /h (200 Pa)	70	68	91	94	65	45

MODIFICATIONS

DUPLEX BASIC - BASIC UNIT



Basic configuration

DUPLEX 1400-10100 Basic

The compact unit consists of supply and exhaust centrifugal fans with electric motors in anti-vibration mounting, removable cross-flow air-to-air heat recovery core assembled from thin plastic plates, removable G4, M5 or F7 supply and exhaust air filters, and a condensate pan with flexible hose. A front door enables easy access to all built-in components and filters.

DUPLEX 12100-15100 Basic

The unit consists of 3 separate sections:

- 1 - supply free-wheel fan with electric motors in anti-vibration mounting, removable supply filter G4, M5 or F7
- 2 - cross-flow heat recovery exchanger
- 3 - exhaust free-wheel fan with electric motors in anti-vibration mounting, removable exhaust filter G4, M5 or F7

A front door enables easy access to all built-in components and filters.

DUPLEX xxxx Basic



Fans

All units are equipped with high-efficiency fans (ebm-papst and Ziehl Abegg) with free-running impellers and backward curved blades. Whole range of DUPLEX 1400 to 10100 Basic fans meets the requirements of the European directive ErP 2015.

Me.xxx; Mi.xxx



Heat recovery core

For every DUPLEX 1400-10100 Basic unit size are two heat recovery exchanger types available (K750.F and K750.G), that differs in heat recovery efficiency and pressure loss, for DUPLEX 12100 and 15100 Basic units is available single type K900.A.

K.750.x, K.900.A

DUPLEX BASIC - MODIFICATION DESCRIPTION



By-pass ("B")

By-pass of the plate heat recovery core on supply air side. By-pass consists of an opposed-blade damper and an actuator. It is fitted next to the recovery core inside the unit; it does not increase size of the unit. The standard actuator is BELIMO 24 V; other types are available upon request.

B.x

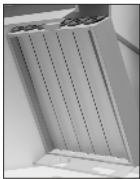

Mixing damper ("C")

The mixing damper is used to mix exhaust and supply air. Circulation valve consists of an opposed-blade damper and actuator. It is fitted next to the recovery core inside the unit, it does not increase the size of the unit. The standard actuator is BELIMO 24 V; other types are available upon request.

C.x



Hot water heating coil ("T")

Built-in water-to-air three-row (possibly multi-row) heating coil; made of copper pipes and aluminum fins. Designed for systems up to 110 °C and 1,0 MPa. The coil is standardly equipped with flexible connection and a steam-gas capillary thermostat for freeze protection. Units in modification T (with heating coil) must be equipped with e, supply air shutoff damper; an actuator with spring-return function is recommended. A coil hydraulic kit for heating capacity control of RE-TPO4 or RE-TPO3 type can be supplied with the coil upon request.

T.x

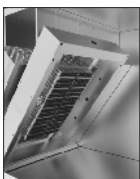

Electric heating coil ("E")

Integrated electric heating coils consist of PTC (Positive Temperature Coefficient) cells; they are generally used to heat up supply air. By default, electric heating coils always include protective thermostats (operational as well as emergency with manual reset) and regulation module KM featuring power switching elements with so called "zero" switching function (SSR). Built-in electric heating coils are offered in the 1400-10100 Basic units in two power options (basic and powerful). For more information please refer to the selection software DUPLEX.

T.x



Direct expansion (DX) coil ("CHF")

A built-in coil made of copper pipes and aluminum fins, including a condensate pan with individual condensate drainage and a pressure switch for freeze alarm. Three- or multi-row coils with various evaporate temperature are chosen depending on capacity required, refrigerant type and air parameters. Optionally it is possible to deliver double-circuit evaporator in division 1:1 or 1:2, or completely atypical with needed capacity.

CHF.x



Chilled water cooling coil ("CHW")

A built-in coil made of copper pipes and aluminum fins, including a condensate pan with individual condensate drainage. Three- or multi-row coils are chosen depending on capacity required, cooling medium type and air parameters. The cooling coil can be equipped with the R-CHW2 or R-CHW3 hydraulic kit on request.

CHW.x

OTHER OPTIONAL ACCESSORIES (BASIC OVERVIEW)

Ke.xxx; Ki.xxx

Shutoff damper e₁; i₁

Shutoff dampers standardly fitted with BELIMO actuators are located in the air inlet port. The following damper types are available:

- **fresh air damper e₁** - mandatory for C modification (with mixing damper) and T modification (with heating coil)
- **exhaust air damper i₁**

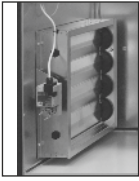

Fe.xxx; Fi.xxx

Air filtration

All DUPLEX Basic units can be equipped with supply or exhaust air filtration of M5 or F7 class instead of standard G4 class. Pressure drop of the filter is then 50 to 100 Pa (clean filter) depending on air flow rate, unit type and dirt accumulated.

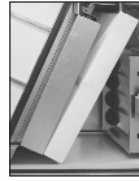

RE-TPO.x

Heating coil hydraulic kit

Its function is to control heating capacity of a heating coil. It consists of a three-speed pump, two globe shutoff valves and connection pipes. Further equipment depends on the type:

- **RE-TPO4** - four-way mixing valve with an actuator for digital control system
- **RE-TPO3** - three-way mixing valve with an actuator for digital control system



R-CHW.x

Cooling coil hydraulic kit

Its function is to control cooling capacity of a chilled-water cooling coil. It always consists of two globe shutoff valves and connection pipes. Further equipment depends on the type:

- **R-CHW3** - three-way mixing valve with an actuator
- **R-CHW2** - throttling valve with an actuator for digital control system



MFF

Tube manometers

Accessory for filters for simple view of current pressure drop. The tube manometers are obligatory for hygienic unit design in accordance with the VDI 6022.

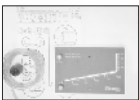

FK.x

Spare cartridge filters

Replacement filter cartridges in different sizes based on the unit type. Available in G4, M5 and F7 filtration class.



H.P

Flexible connections

Round and rectangular ports can be equipped with flexible connections upon request.



Delivery of disassembled unit

All units can be delivered dismantled on request. The unit is to be assembled by rivets and bolts directly on site, therefore the unit can be installed in inaccessible location. Casing insulation class T3, thermal bridging class TB2.

TPO

Hot water heating coil (TPO)

Separately supplied coil for installation into round duct. It is suitable for cramped locations, where it is impossible to put the coil inside the unit, as well as for rooftop units. The coil is standardly equipped with the steam-gas capillary thermostat. Capacities and diameters can be found in respective catalogue sheets.



EPO-V

Electric heating coil (EPO-V)

Separately supplied heating coil to be fitted into round or rectangular duct. Capacities and diameters can be found in respective catalogue sheets.



CF.XXX

Constant air flow and pressure

Manometers reading fan pressure together with controls, enables intelligent fan control of preselected airflow. This accessory assumes the unit is equipped with ATREA aMotion digital control system. Using a second manometer (optional accessory) in the supply air duct enables the user to control constant pressure in the supply duct.



EPO-V

Electric preheaters EPO-V

EPO-V electric heating coils to provide the antifreeze protection of the heat recovery exchanger when equal-pressure ventilation is continuously required. It is installed inside a duct on the outdoor supply air side of the unit (e₁). This accessory assumes the unit is equipped with ATREA aMotion digital control system.



Hingeless door

When needed it is possible to deliver door without standard hinges - than necessary manipulation space is reduced. DUPLEX 12100 and 15100 Basic are supplied hingeless standardly.

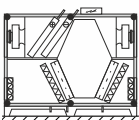

External switchboard

It is possible to supply control module in external version with various cable length.

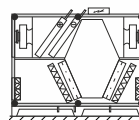

CONTROLS





DUPLEX Basic units are delivered with basic control components or with complete control systems.

There are three types of control systems available (Basic, CPM and aMotion) according to customer needs and an application. The systems also include variety of sensors (temperature, humidity, air quality, CO₂) for effective operation control.

Features of the control systems

- selection of the most suitable and efficient control system at the lowest cost, depending on the application
- control system is integrated with the unit, most components are already wired and checked in factory, thus reducing the risk of incorrect wiring
- no control system project documentation is necessary for standard cases, standardized solutions can be used
- simple wiring, system simplicity, error indication
- qualified technical support and consulting

SUMMARY OF DUPLEX BASIC CONTROL SYSTEMS

Type	Use	Controller
“Basic” controls	<ul style="list-style-type: none"> - all electrical components are wired to a junction box terminal strip inside or outside the unit - standard components are fans, damper actuators, capillary freeze protection thermostat of hot water heating coil - more components are included upon customer's request (exact actuator type, sensors, thermostats, pressure switches etc.) - suitable for applications with separate delivery of control system; e.g. large buildings with central control system etc. 	<div style="border: 1px solid black; padding: 5px; text-align: center;"> basic version (fans, actuators, thermostats, pressure switches and others on request) </div> <div style="text-align: center;"> ↑ ↓ </div> <div style="border: 1px solid black; padding: 5px; text-align: center;"> Supervisory control system </div>
“CPM” controls	<p>Standard functions</p> <ul style="list-style-type: none"> - EC fan speed control (stepless) - automatic by-pass damper position - frost protection of heat exchanger - switching of electric or water heater - input for external switch - inlet and outlet shut-off damper control - minimum and maximum fan speed preselection - analogue input (0-10 V) for air quality sensor (CO₂, RH) - outputs for controlling electrical preheater and heater (pulse switched 10 V) or water heater (controlled by 0-10 V signal) - outputs for controlling cooling (direct or water), eventually heat pump <p>Controller CPM</p> <ul style="list-style-type: none"> - fully graphic touchscreen - weekly program - „party” mode - „holiday” mode - filter change notice - automatic operation based on constant signal - e.g. constant pressure <p>Controller CP 10 RA</p> <ul style="list-style-type: none"> - rotatable controller 	<div style="text-align: center;">  <p>CPM controller with touchscreen display</p> </div> <div style="text-align: center;">  <p>CP 10 RA with mechanical knob</p> </div>
“aMotion” controls	<p>Standard aMotion control functions</p> <p>Elementary aM-CE basic module</p> <ul style="list-style-type: none"> - EC fans speed control (according to selected mode) - Automatic heat and cool recovery control (by-pass control) - Evaluates and prevents all emergency conditions according to the measured values - Possibility of setting basic and user scenes and weekly calendars to select modes, power, temperatures and other functions - Ethernet connection for communication over the Internet - Inputs for external signals - control e.g. from kitchens, toilets and similar - Possibility of connecting air quality sensors (e.g. CO₂ concentration or relative humidity) either by contact, 0-10V voltage, or via the bus. - Outputs for continuous control of electric preheater and heater (pulse switched 10 V) - Possibility of connecting up to two controllers of different types - Connection to supervisory control system via Modbus TCP protocol <p>Legendary aM-CL advanced module (with all functions from Elementary aM-CE module and additional options below)</p> <ul style="list-style-type: none"> - Control of systems with VAV boxes - Control of systems with heat sources (heat pumps, heat accumulators etc.) - Communication by BACnet protocol over the bus - Possibility of connecting more than two controllers - More than 4 external bus elements (controllers, CO₂ sensors, outdoor temperature sensors,...) - Multiple adjustable scenes (more than 10) - More than 2 user calendars - More than 4 users (excluding service access) <p>Additional module aM-IO18</p> <ul style="list-style-type: none"> - Inputs for 4 external signals - control from kitchens, toilets and similar - Hot water heater control (0-10 V) - Control of circulation modes <p>Additional module aM-IO12</p> <ul style="list-style-type: none"> - Control of cooling (direct and water) and heat pumps - Rotary regenerator <p>Additional aM-XCF</p> <ul style="list-style-type: none"> - Unit control based on flow measurement <p>Additional RD-K module</p> <ul style="list-style-type: none"> - Additional inputs and outputs significantly expanding the control system functionality <p>BACnet / KNX converter</p> <ul style="list-style-type: none"> - Connection to the superior system via BACnet or KNX protocol 	<p>aTouch (touchscreen)</p> <div style="text-align: center;">  </div> <p>aDot (touchscreen)</p> <div style="text-align: center;">  </div> <p>aSpace (internet interface)</p> <div style="text-align: center;">  </div>