

DUPLEX Inter-H

Brand new decentral ventilation unit with heat recovery for under-ceiling installation

Determination

Indoor ventilation units DUPLEX Inter-H are designed for balanced-pressure ventilation in classrooms, open area offices, facilities, restaurants, retail units and everywhere else where direct installation to the areas where the low noise is required.

Basic description

The units have high heat recovery efficiency, very low noise levels, low installed power input and minimum installation and design planning requirements.

The units are produced in two sizes: **DUPLEX 770 Inter-H** and **1000 Inter-H**.

The units are fitted with the top-of-the-range ATREA aMotion control system for running all necessary functions.

DUPLEX Inter-H units include flexibly mounted EC fans, a counterflow heat recovery exchanger, a slide-out supply air filter, a heat recovery exchanger bypass, self-powered shut-off dampers and a control box. The drainless condensate pan is heated using an electric cell with automatic switching function.

In the unit there are placed splitter acoustic attenuators, exhaust and supply filter and integrated CO₂ sensor as a standard.

Compliance with European standards

- Commission (EU) Regulation No. 1253/2014 (Ecodesign) for 2018
- Casing characteristics according to EN 1886
- EC motors compliant with ErP 2015
- Hygienic design according to VDI 6022

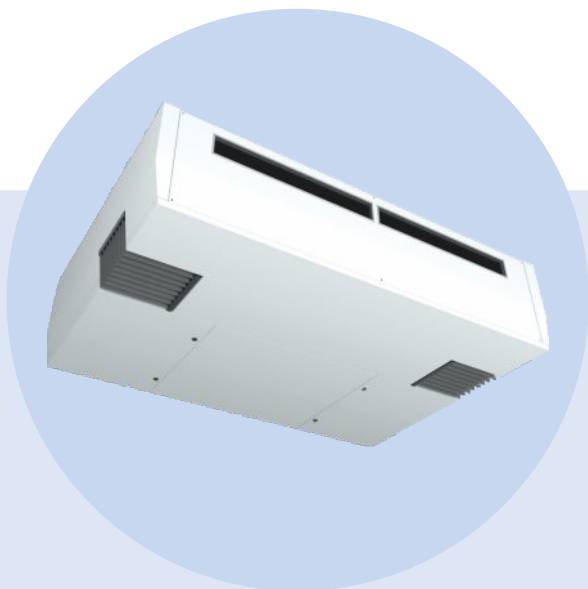

Advantages of DUPLEX Inter-H units

- The most silent school unit on the market – sound pressure 29 dB(A) at a flow rate of 650 m³/h
- Air flow up to 1100 m³/h
- High heat recovery efficiency of up to 93 %
- Height only 550 mm
- Demanding condensate drainage eliminated (!)
- Integrated preheater as standard included in the unit price
- Integrated infrared CO₂ sensor included in the unit price
- 4 options of the connection port position (to be decided at the installation)
- An option for unit to be partly installed in the suspended ceiling (to be decided at the installation)
- Quick and easy installation – original installation kit
- Unit to be split into 2 parts for easier handling and manipulation (through the door)
- Interior design – additional cladding option installation after the unit has been commissioned after the very final phase of the construction works
- Optional reheater – easily to be fitted additionally
- Full bypass for free-cooling (heat recovery exchanger is 100% bypassed)
- Built-in aMotion controls – web server, ModBus, remote service access, alarm notification, optional controllers
- Service switch – disconnects the unit from power supply
- Limit switch (automatically switches off the unit when the door is opened)
- VDI 6022 – manufactured in full compliance with requirements

OPERATING MODES

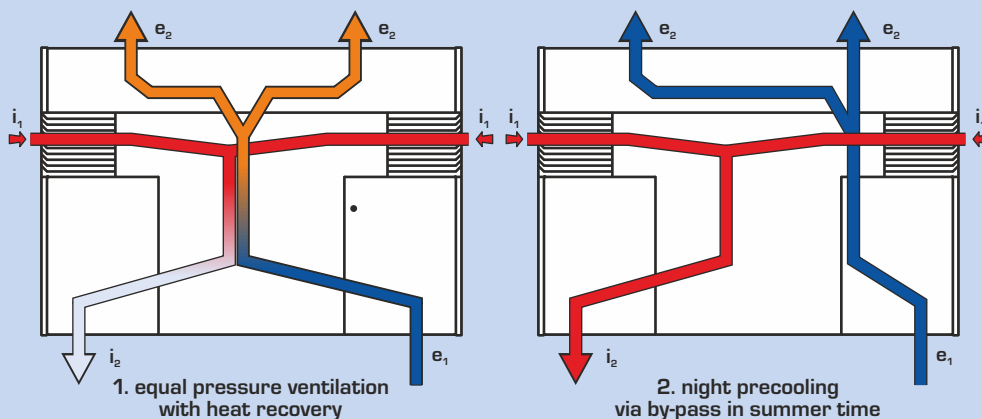

SELECTION SOFTWARE



For the detailed design of DUPLEX series units, accessories and control systems we recommend using our dedicated design software. You can find it on our website at www.atrea.eu.



VENTILATION UNITS WITH HEAT RECOVERY

ATREA s.r.o., Čs. armády 32
466 05 Jablonec n. Nisou
Česká republika



Tel.: +420 483 368 133

Fax: +420 483 368 112

E-mail: atrea@atrea.eu

www.atrea.eu

PERFORMANCE GRAPHS

TECHNICAL DATA

DUPLEX Inter-H		770	1 000
Maximal air-flow rate	m ³ /h	950	1,100
Nominal air-flow rate	m ³ /h	730	950
Heat recovery efficiency ¹⁾	%	up to 93 %	
Power consumption – fans	W	see graph	
Electric preheater	W	2,200	
Voltage	V	230	
Frequency	Hz	50	
Fan speed – max	min ⁻¹	1,910	
Filter class	-	ePM10 50 % (M5) / ePM10 50 % (M5), optional ePM1 55 % (F7)	
Electric reheater	W	optional	
Built-in control system – auto	-	CO ₂	
100 % by-pass	-	standard	
Weight	kg	267	278

¹⁾ According to air volume

HEAT RECOVERY EFFICIENCY

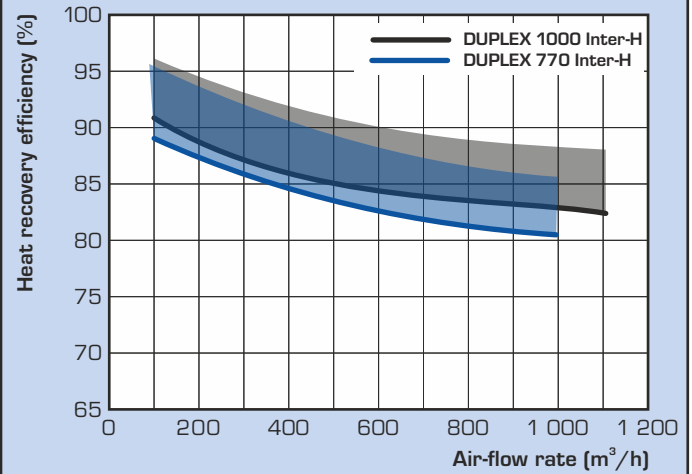

PERFORMANCE SUMMARY

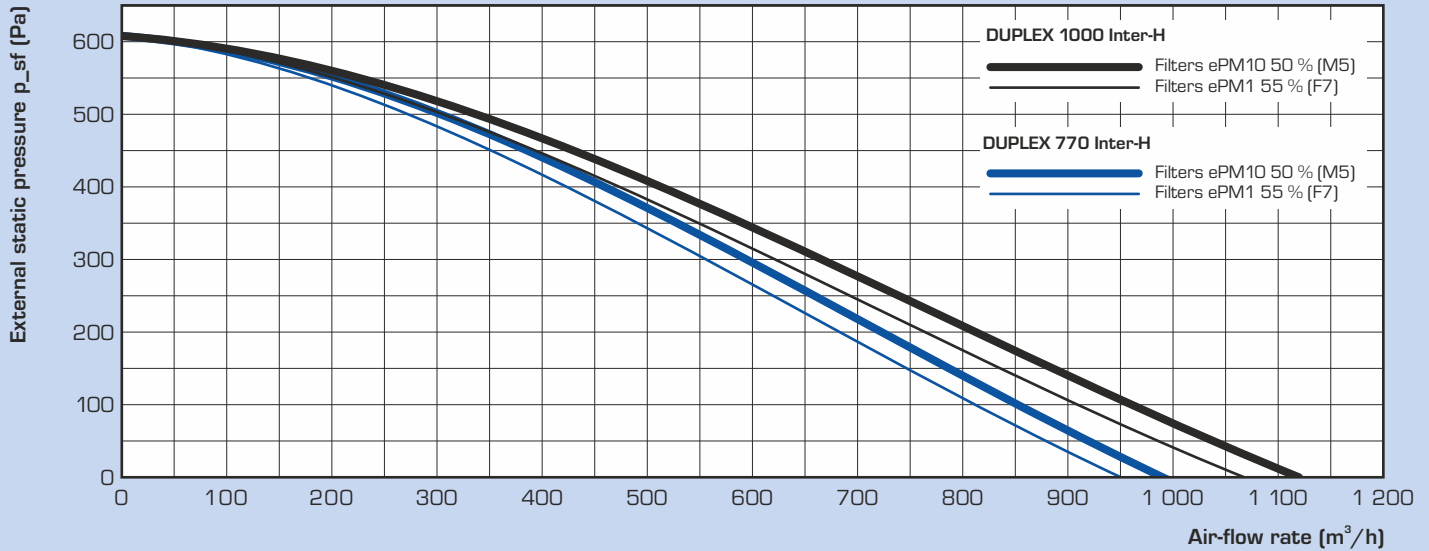

POWER INPUT CHARACTERISTICS

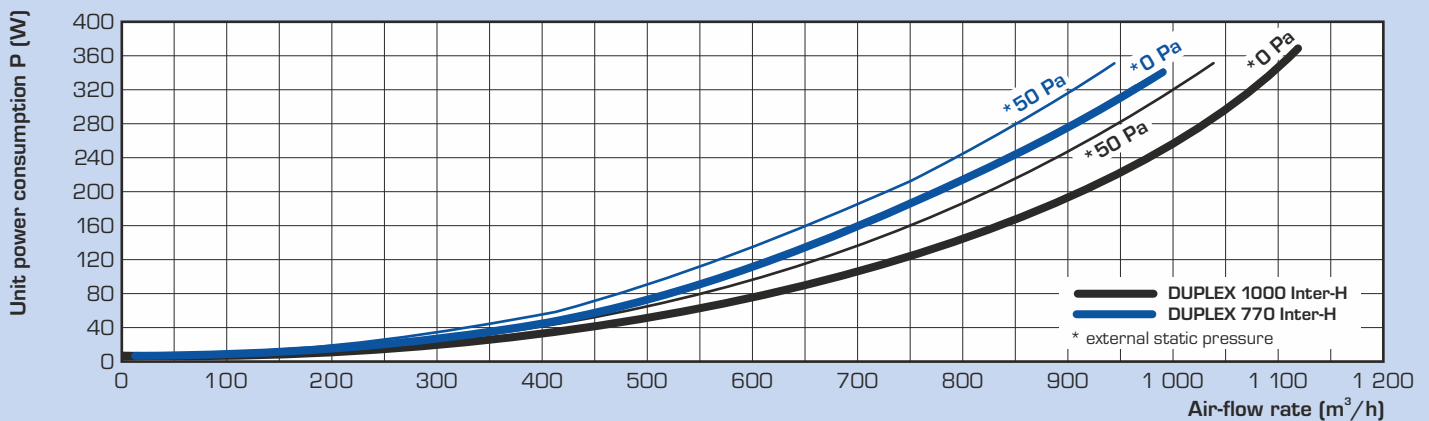

BASIC DIMENSIONS

Front panel can be turned over as an option when the unit is partly installed in the suspended ceiling

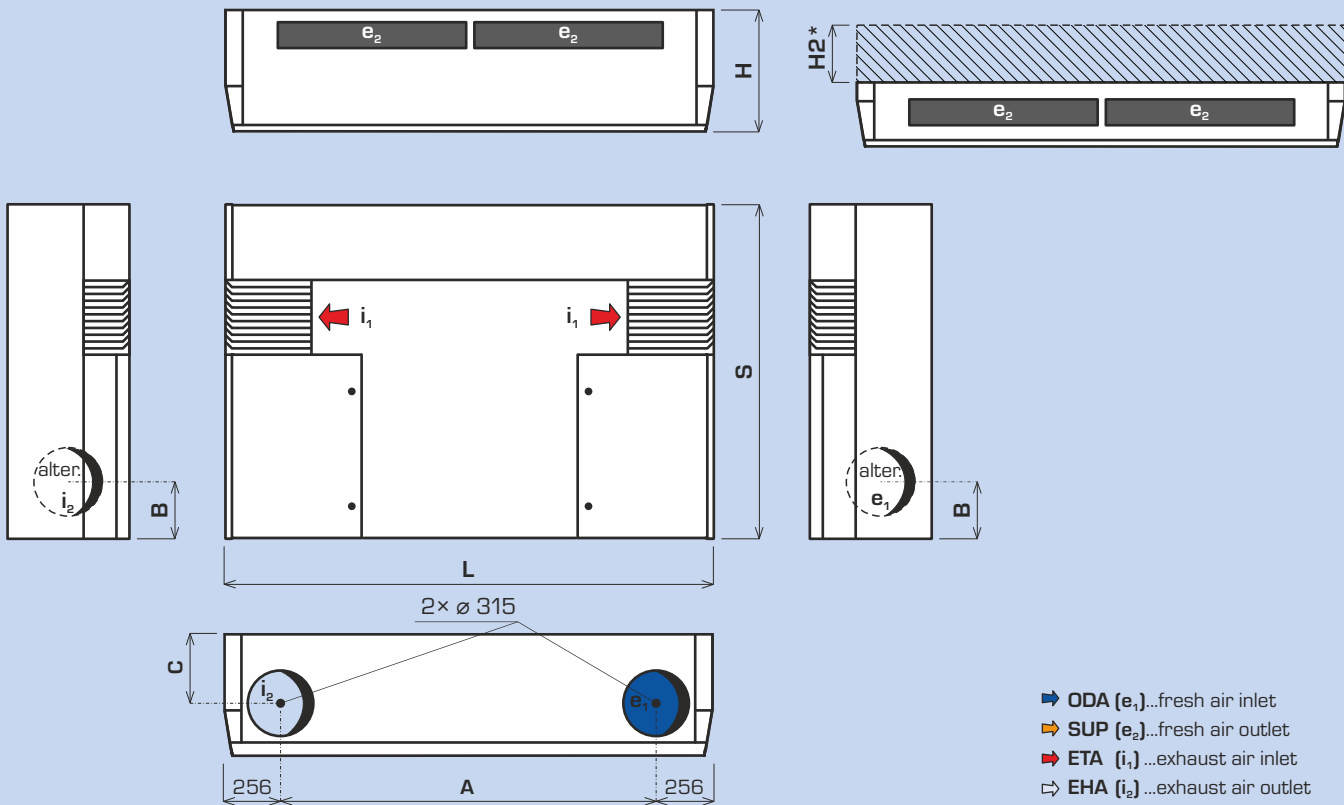

* The lowest possible edge of the suspended ceiling

Unit DUPLEX		L	S	H	H2	A	B	C
770 Inter-H	mm	1,940	1,527	550	max. 315	1,428	320	227
1000 Inter-H	mm	2,222	1,527	550	max. 315	1,710	320	227

BASIC COMPONENTS



Legend:

- 1 Counter-flow plastic exchanger
- 2 EC fan (exhaust)
- 3 EC fan (supply)
- 4 Supply air filter
- 5 Exhaust air filter
- 6 Supply splitter acoustic attenuators
- 7 Control box
- 8 Main switch
- 9 Mechanical shut off dumpers with return springs

HANDLING SPACE

DUPLEX Inter-H units must be installed with the prescribed handling space around the unit in mind.

Handling space under the unit must be maintained for opening the front door, replacing filters and providing servicing and installation access to each unit part.

Each drawing shows the minimum handling space.

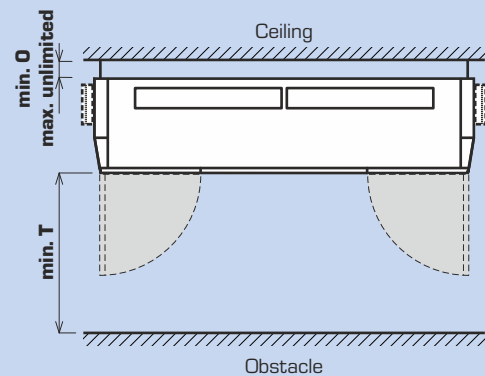

Unit DUPLEX		T
770 Inter-H	mm	690
1000 Inter-H	mm	690

UNIT CASING

UNIT CASING OPTIONS

BASIC COMPONENTS

The units can be supplied in various ports configurations. Possible configurations and related order numbers can be found in the diagrams below.



DUPLEX Inter-H (zinc, ready for casing)

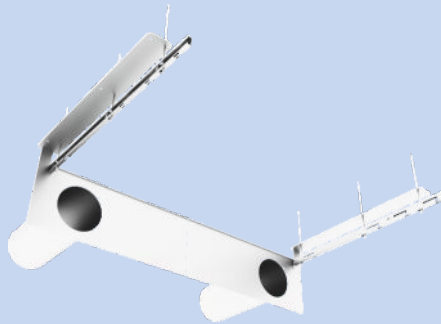

Complete mounting kit for Inter-H



Small mounting kit for Inter-H



main parts



left side - full

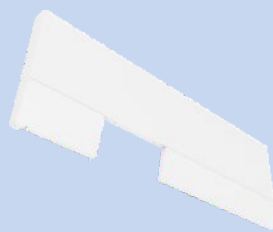

right side - full



left side - open

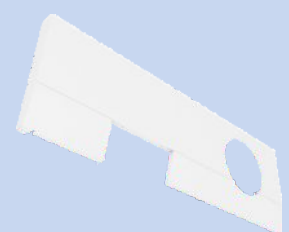

right side - open

Unit casing - white colour -

TOP VIEW
(FLOOR PLAN)

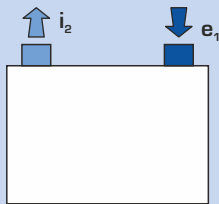

	770	1000
DUPLEX Inter-H (incl. preheater, zinc, ready for casing)	A351001	A351000
Mounting kit - complete / small	A351010 / A351009	
Unit casing - white colour - main parts	A351025	A351020
Unit casing - white colour - right side - full	A351021	
Unit casing - white colour - left side - full	A351023	

TOP VIEW
(FLOOR PLAN)

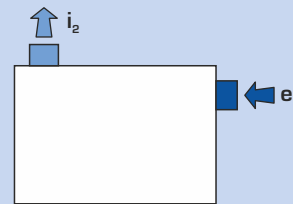

	770	1000
DUPLEX Inter-H (incl. preheater, zinc, ready for casing)	A351001	A351000
Mounting kit - complete / small	A351010 / A351009	
Unit casing - white colour - main parts	A351025	A351020
Unit casing - white colour - right side - open	A351022	
Unit casing - white colour - left side - full	A351023	

TOP VIEW
(FLOOR PLAN)

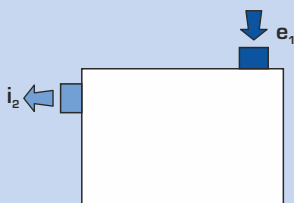

	770	1000
DUPLEX Inter-H (incl. preheater, zinc, ready for casing)	A351001	A351000
Mounting kit - complete / small	A351010 / A351009	
Unit casing - white colour - main parts	A351025	A351020
Unit casing - white colour - right side - full	A351021	
Unit casing - white colour - left side - open	A351024	

TOP VIEW
(FLOOR PLAN)

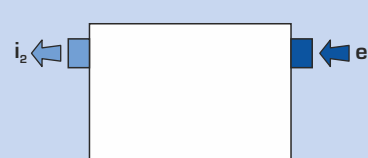

	770	1000
DUPLEX Inter-H (incl. preheater, zinc, ready for casing)	A351001	A351000
Mounting kit - complete / small	A351010 / A351009	
Unit casing - white colour - main parts	A351025	A351020
Unit casing - white colour - right side - open	A351022	
Unit casing - white colour - left side - open	A351024	

DETAIL OF INSTALLATION AND FACADE PENETRATION

MOUNTING OPTIONS:

WALL MOUNTING (MOUNTING KIT - COMPLETE A351010)

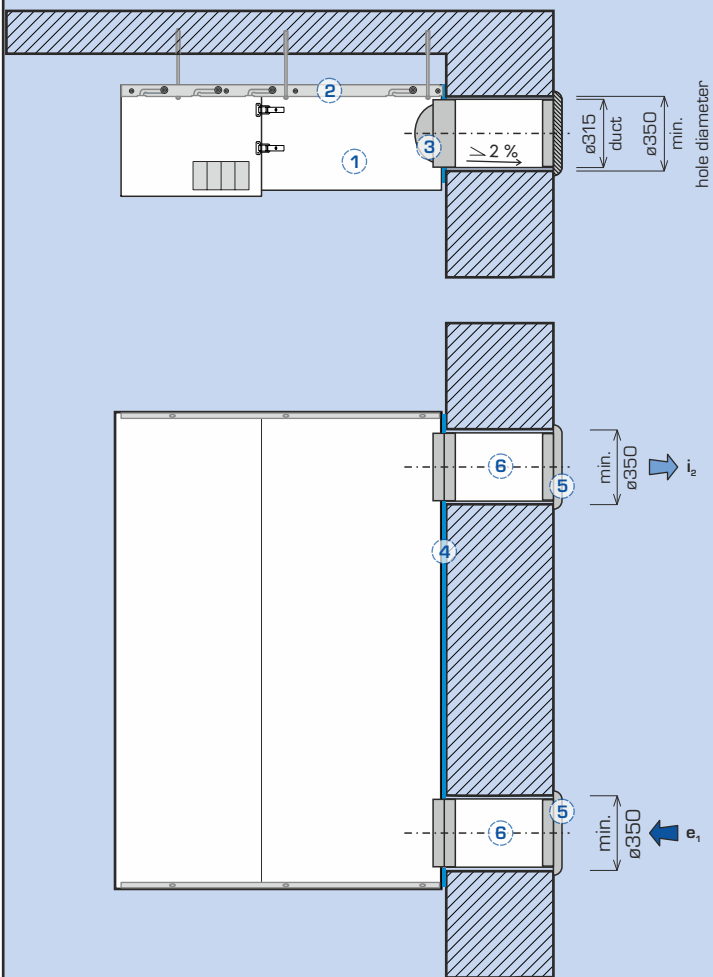

MIDDLE ROOM MOUNTING (MOUNTING KIT - SMALL A351009)

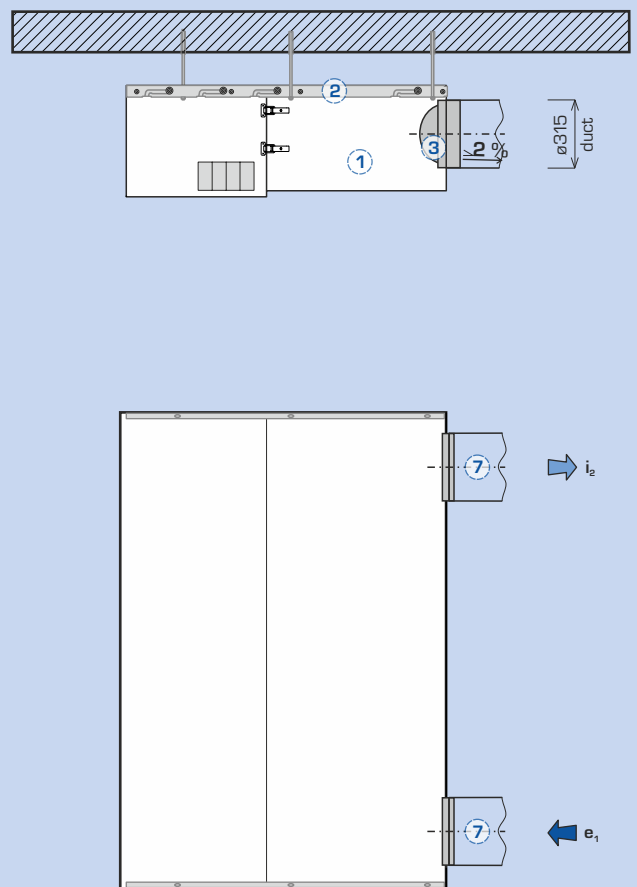

1 DUPLEX Inter-H

2 Suspension rail *
the connecting material for mounting the suspension rail is not part of the delivery, the unit can be suspended from the ceiling with any distance between the ceiling and the unit

3 Counter-flow flap (2x)**
also serves as an internal coupling between the unit port and the pipe bushing, part of the delivery

4 Mounting sheet metal template *

* Part of the complete mounting kit

** Part of the unit

5 Facade outlet
not a part of the delivery

6 Duct passage through the perimeter wall (2x)*
length 700 mm, \varnothing 315 mm, shorten to the required length during assembly, install at a 2% slope towards the exterior, fix with low-expansion PU foam, min. diameter of the hole in the perimeter wall 350 mm

7 Duct DN315
(not included in the delivery)

DUPLEX 1000 INTER-H

The acoustic power to surrounding with ePM10 50 % (M5) filters

Acoustic power	Flow rate [m ³ /h]	External pressure [Pa]	L _{wA} [dB(A)]	L _w [dB]								L _{pA} 3 m [dB(A)]	L _{pA} 1 m [dB(A)]
				63 Hz	125 Hz	250 Hz	500 Hz	1000 Hz	2000 Hz	4000 Hz	8000 Hz		
L _{wA} to surrounding - point 1	900	50	41	56	55	45	28	<25	<25	<25	<25	21	30
L _{wA} to surrounding - point 2	800	40	39	55	52	44	26	<25	<25	<25	<25	19	28
L _{wA} to surrounding - point 3	700	30	38	54	51	43	<25	<25	<25	<25	<25	18	27
L _{wA} to surrounding - point 4	600	22	36	51	50	39	<25	<25	<25	<25	<25	16	25
L _{wA} to surrounding - point 5	500	15	34	48	49	35	<25	<25	<25	<25	<25	14	23
L _{wA} to surrounding - point 6	400	10	33	45	48	31	<25	<25	<25	<25	<25	13	22

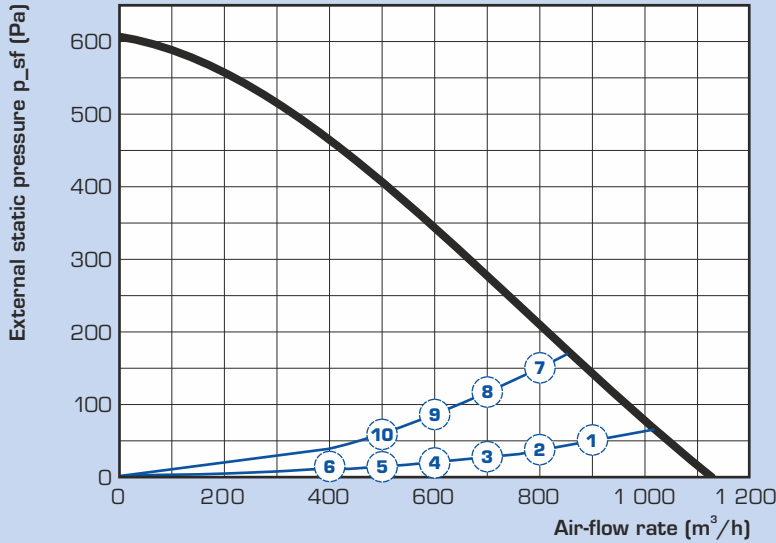

Working point	Sound pressure at distance of 3 m / 1 m [dB(A)]
1	21 / 30
2	19 / 28
3	18 / 27
4	16 / 25
5	14 / 23
6	13 / 22
7	20 / 29
8	18 / 28
9	17 / 26
10	15 / 25

DUPLEX 770 INTER-H

The acoustic power to surrounding with ePM10 50 % (M5) filters

Acoustic power	Flow rate [m ³ /h]	External pressure [Pa]	L _{wA} [dB(A)]	L _w [dB]								L _{pA} 3 m [dB(A)]	L _{pA} 1 m [dB(A)]
				63 Hz	125 Hz	250 Hz	500 Hz	1000 Hz	2000 Hz	4000 Hz	8000 Hz		
L _{wA} to surrounding - point 1	700	50	43	60	55	48	34	<25	<25	<25	<25	23	32
L _{wA} to surrounding - point 2	600	37	42	57	55	48	33	<25	<25	<25	<25	22	31
L _{wA} to surrounding - point 3	700	26	41	56	54	43	32	<25	<25	<25	<25	21	30
L _{wA} to surrounding - point 4	600	16	40	56	54	44	31	<25	<25	<25	<25	20	29
L _{wA} to surrounding - point 5	500	9	40	55	53	43	31	<25	<25	<25	<25	19	29
L _{wA} to surrounding - point 6	400	4	39	55	48	42	31	<25	<25	<25	<25	19	28

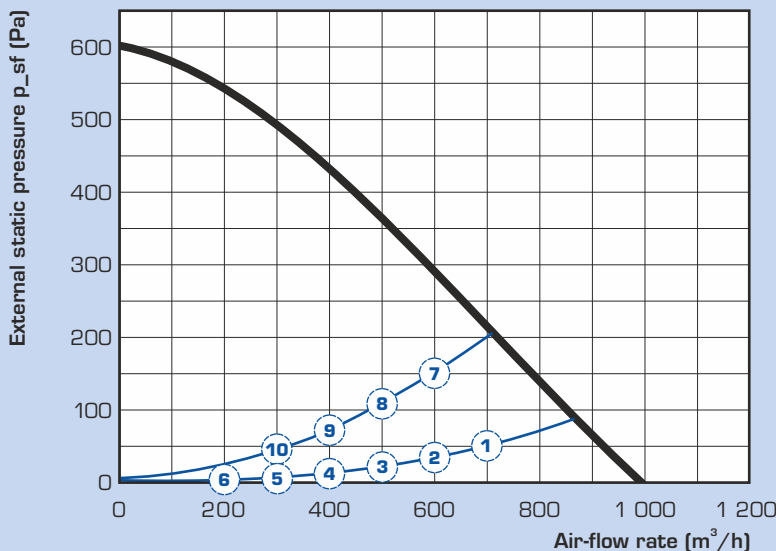

Working point	Sound pressure at distance of 3 m / 1 m [dB(A)]
1	23 / 32
2	22 / 31
3	21 / 30
4	20 / 29
5	19 / 29
6	19 / 28
7	25 / 34
8	21 / 31
9	20 / 29
10	19 / 28

DUPLEX INTER - BASIC UNIT

DUPLEX Inter-H



DUPLEX Inter-H

The basic compact unit configuration includes supply and extractor fans with free-running impeller and anti-vibration mounting, a removable counterflow heat recovery exchanger from thin-walled plastic panels, slide-out supply and extraction air filters (filter class ePM10 50 % (M5) or ePM1 55 % (F7)) and a condensate pan. The door provide easy access to all integrated components.



Fans

DUPLEX Inter-H units feature high-efficiency fans with free-running impeller and backward-curved blades. The fans comply with the requirements of the ErP 2015 European standard.



Heat recovery exchanger

The counterflow-type heat recovery exchanger is made of plastic and is highly efficient. The efficiency rates of plastic heat recovery exchangers in DUPLEX Inter-H are up to 93 %.

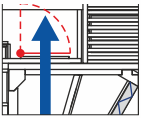

Bypass damper

A plate heat recovery exchanger bypass including actuator. When the bypass opens, the flow through the heat recovery exchanger automatically closes to eliminate heat transfer.



Electric pre-heater

2.2 kW electric pre-heaters EDO.INT 2,2 are included as standard in the basic configuration of DUPLEX Inter-H unit. Preheating is operated by the unit's control system in such a way so as to prevent heat recovery exchanger freezing.



CO₂ concentration sensor

DUPLEX Inter-H units include a CO₂ concentration sensor as a standard basic configuration feature. It is an NDIR type sensor with infrared sensor and is integrated in the unit in the exhaust air intake. It enables coupled control based on current room occupancy.

DUPLEX INTER-H - OPTIONAL ACCESSORIES



- Electric re-heaters EDO.INT and 1,1 EDO.INT 2,2 are determined for supply air re-heating with power of up to 2.2 kW
- Designed for **integration in the unit** as an optional accessory to be installed at the set position inside the unit including the mounting frame

OVERVIEW OF ORDER NUMBERS FOR DUPLEX INTER-H

	DUPLEX 770 Inter-H (incl. preheater, zinc, ready for casing)	Ord. No. A351001		aTouch 4,3 controller with 4.3" color touch screen (for aMotion L, E regulation)	Ord. No. A145500
	DUPLEX 1000 Inter-H (incl. preheater, zinc, ready for casing)	Ord. No. A351000			
	Mounting kit - complete	Ord. No. A351010		aDot (B) design controller with display - basic print - black (for aMotion L, E regulation)	Ord. No. A145550
	Mounting kit - small	Ord. No. A351009		aDot (W) design controller with display - basic print - white (for aMotion L, E regulation)	Ord. No. A145551
	Unit casing - white colour - main parts (770 IH)	Ord. No. A351025		FK 1000 INT - M5	Ord. No. A351090
	Unit casing - white colour - main parts (1000 IH)	Ord. No. A351020		FK 1000 INT - F7	Ord. No. A351091
	Unit casing - white colour - right side - full	Ord. No. A351021		FK 900 cartridge M5 (900, 1000 M, 800 ME)	Ord. No. A132767
	Unit casing - white colour - right side - open	Ord. No. A351022		Electric heater EDO.INT 1,1 kW (770 IH, for additional assembly)	Ord. No. A351013
	Unit casing - white colour - left side - full	Ord. No. A351023	Electric heater EDO.INT 2,2 kW (1000 IH, for additional assembly)	Ord. No. A351011	
	Unit casing - white colour - left side - open	Ord. No. A351024			

CONTROL SYSTEM

As a standard feature DUPLEX Inter-H units include the top-of-the-range aMotion digital control system enabling remote access through a web-based server.

The aMotion type digital control module is the latest in operation control. It provides all basic functions and also includes a wide range of other inputs and outputs for connection to sensors. All optional components including the power supply are connected through the terminal board on the top section of the unit.

Also included as standard is a built-in smoke detector which disconnects the unit if smoke is drawn in.

AMOTION CONTROL SYSTEM FOR DUPLEX INTER-H UNITS

Control system „aMotion“

Standard functions of the aMotion control system

- EC fan speed control (according to mode settings)
- Automatic bypass damper position control (heat and cold recovery)
- Critical condition assessment and prevention based on temperature readings
- Weekly ventilation programme and temperature setting
- A built-in web server and Ethernet interface for communication with remote access through the Internet
- 4 contact inputs
- Power inputs for switching using 230 V voltage (4 inputs - 3 delayed, 1 immediate)
- An option to connect two CO₂ or relative humidity sensors, up to two sensors with a contact or 0-10 V input
- Outputs for controlling the electrical pre-heater and heater (impulse switching by 10 V) or hot-water air heater (controlled by 0-10 V signal)
- Operation of the unit in selected modes - balanced-pressure ventilation / night pre-cooling / overpressure ventilation
- Automatic switching between modes according to temperature settings
- Power control according to current CO₂ concentration including automatic power increase
- Automatic switching between heating and non-heating seasons
- Web server / ModBUS communication as a standard feature

BACnet / KNX converter

- An optional converter for connection to a parent system using a BACnet or KNX protocol

CO₂ concentration

- Optional sensor-based automatic operation - CO₂ concentration (one sensor supplied), another air quality, relative humidity or VOC sensor can be connected (optional accessory)

EPS

- Optional EPS signal connection (electronic fire alarm signal) for disconnecting the unit in the event of fire alarm

Smoke detector

- A built-in smoke detector is also a standard feature of the unit

aTouch (touch-screen)



aDot (touch-screen)



aSpace (internet interface)

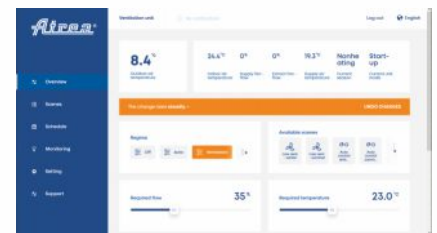

CO₂ sensor (1× as standard)

